



LIPPERT
COMPONENTS®



Correct Track™

Installation and Owner's Manual

(For Aftermarket Applications)

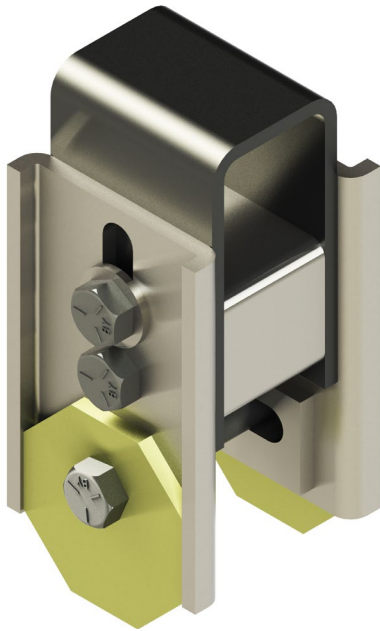

Table of Contents

Introduction	2	Customer Form	12
Safety Information	2	Excessive Tire Wear, suspension damage	12
Parts List	3	Conducting Inspection & Written Report	13
Triple Axle	3	Safety Inspection Report	13
Tandem Axle	3	Check, Correct, Note	13
Single Axle	3	Tire Inspection	13
Prior to Installation	4	Inspect Suspension Components	13
Preparation	4	Suspension Components Inspection	13
Installation	6	Notes	14-16
Manual Measurement	7		
Laser Measurement Kit Assembly	8		
Travel Trailer	8		
Fifth-Wheel	9		
Laser Measurement Procedure	10		
Adjustment Procedure	11		



LIPPERT
COMPONENTS®

Correct Track™

Installation and Owner's Manual

(For Aftermarket Applications)

Introduction

Correct Track by Lippert Components provides a simple way to correct a misaligned trailer suspension system. Misaligned axles and suspension can be caused by worn components, hitting road hazards or unbalanced RV weight. Adding heavy appliances and cargo can cause unbalance within the trailer. Correct Track can be used to adjust RV trailer alignment to provide a smoother ride and prevent premature tire wear.

Benefits:

- Can improve fuel economy
- Tires run smoother and cooler
- Helps to decrease uneven tire wear
- Trailer tows with the tow vehicle, not against it
- Prevents vibrations, protecting RV equipment from damage

Safety Information

NOTE: This manual provides general installation procedures. Many variables can change the circumstances of the procedure, i.e., the degree of difficulty involved in the service operation and the ability level of the individual performing the operation. This manual cannot begin to plot out procedures for every possibility, but will provide the general instructions for effectively installing the system. In the event the skill level required is too advanced or the procedure too difficult, a certified technician should be consulted before performing the necessary service. Failure to correctly install the system may result in voiding the warranty, inflicting injury or even death.

⚠ WARNING

THE "WARNING" SYMBOL ABOVE IS A SIGN THAT AN INSTALLATION PROCEDURE HAS A SAFETY RISK INVOLVED AND MAY CAUSE DEATH OR SERIOUS INJURY IF NOT PERFORMED SAFELY AND WITHIN THE PARAMETERS SET FORTH IN THIS MANUAL. ALWAYS WEAR EYE PROTECTION WHEN PERFORMING THIS INSTALLATION PROCEDURE. OTHER SAFETY EQUIPMENT TO CONSIDER WOULD BE HEARING PROTECTION, GLOVES, AND POSSIBLY A FULL FACE SHIELD, DEPENDING ON THE NATURE OF THE INSTALLATION PROCEDURE.

⚠ WARNING

THE TRAILER MUST BE SUPPORTED PER MANUFACTURER'S SPECIFICATIONS BEFORE WORKING UNDERNEATH. FAILURE TO DO SO MAY RESULT IN DEATH OR SERIOUS INJURY.

⚠ CAUTION

MOVING PARTS CAN PINCH, CRUSH OR CUT. KEEP CLEAR AND USE CAUTION.



Parts List

Triple Axle

Letter	Part #	Description	Qty
A	140776	Washer; .56 X 1.18 X .1190	16
B	122103	Flange Nut; 7/16" - 20	24
C	280579	Shoulder Bolt; 9/16" X 3.32"	6
D	271254	Shoulder Bolt; 9/16" X 2.82"	18
E	290960	Spring Plate	12
F	290959	Equalizer Plate	4
G	290731	Plate 3.000 X 3.000 PC Yellow	12
H	290967	Tube; 1.875" X 2" X 3"	8
I	294200	Label	2

Tandem Axle

Letter	Part #	Description	Qty
A	140776	Washer; .56 X 1.18 X .1190	12
B	122103	Flange Nut; 7/16" - 20	18
C	280579	Shoulder Bolt; 9/16" X 3.32"	4
D	271254	Shoulder Bolt; 9/16" X 2.82"	14
E	290960	Spring Plate	8
F	290959	Equalizer Plate	4
G	290731	Plate 3.000 X 3.000 PC Yellow	8
H	290967	Tube; 1.875" X 2" X 3"	6
I	294200	Label	2

Single Axle

Letter	Part #	Description	Qty
A	140776	Washer; .56 X 1.18 X .1190	4
B	122103	Flange Nut; 7/16" - 20	6
C	280579	Shoulder Bolt; 9/16" X 3.32"	2
D	271254	Shoulder Bolt; 9/16" X 2.82"	4
E	290960	Spring Plate	4
F	-----	Not Required	---
G	290731	Plate 3.000 X 3.000 PC Yellow	4
H	290967	Tube; 1.875" X 2" X 3"	2
I	294200	Label	2

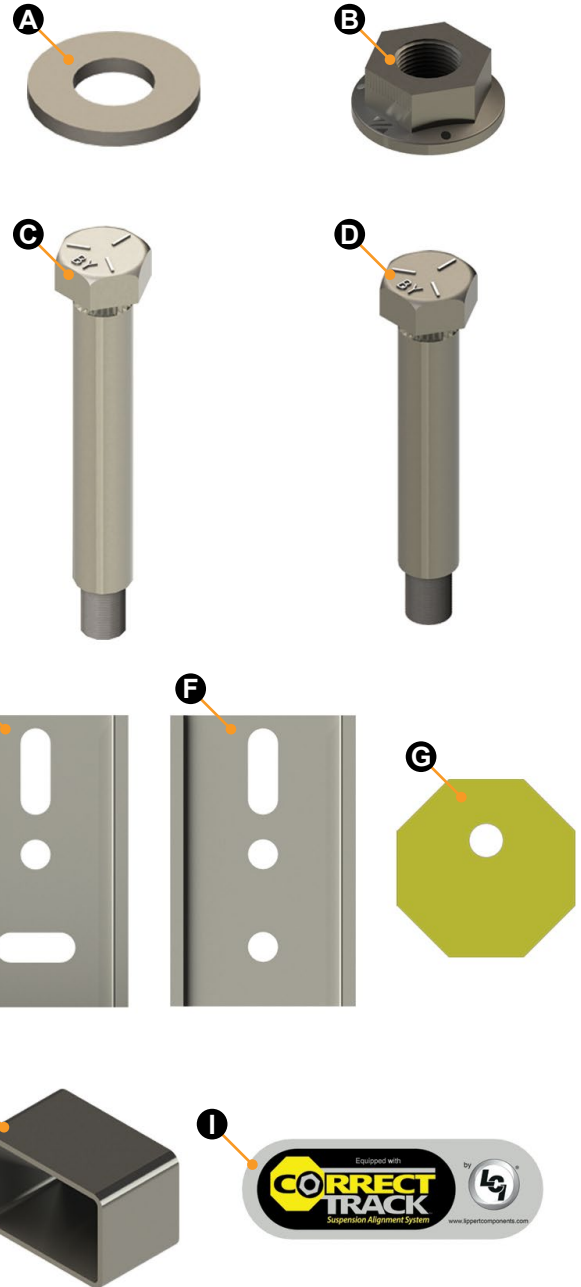



Prior to Installation

Before beginning installation, verify the following conditions do not exist.

Correct Track can not be installed on any frames with boot hangers (**Fig.1**) or any hangers that the minimum distance from the I-Beam to the mounting hole is less than 2 5/8" (**Fig.2**).

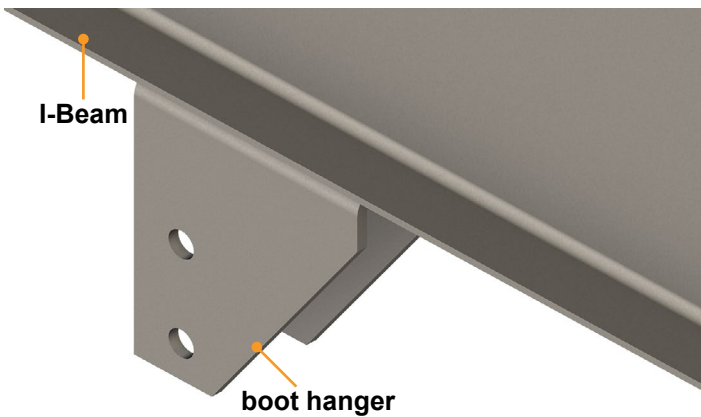

Fig.1

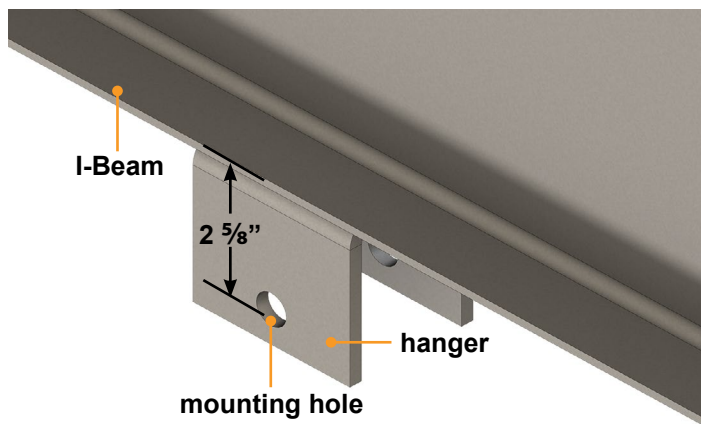

Fig.2

Preparation

1. Support the trailer as per manufacturers specifications.
2. Block tires on one side of the trailer.
3. Remove the wheels on the other side. Using jacks to support the axles, remove the spring bolts from the hangers.
4. We strongly suggest replacing all the bushings with Never Fail Bushings in the springs and the equalizer at this time. Also, if the shackle holes or equalizer/center hanger holes show any signs of wear, replace those parts now. We recommend replacing with Equa-Flex or Center Point Air Ride.
5. With spring bolts removed from hangers, use jacks to lower the axles about 2 inches.
6. Place a hanger plate on the outside of one of the hangers. Align the center hole with the bottom hole of the hanger.
7. Make sure the sides of the hanger and plate are aligned.



8. Use a $\frac{1}{16}$ " drill bit as a guide to score the hanger at the bottom of the vertical slotted hole.

NOTE: Scoring the hanger ensures the $\frac{1}{16}$ " bolt will be properly located at the bottom of the vertical slotted hole.

9. Use a $\frac{1}{4}$ " drill bit to drill a pilot hole. Go through the vertical $\frac{1}{16}$ " x $1 \frac{5}{8}$ " slotted area into the hanger at the centerline of the scored marking (**Fig.3A**).

NOTE: The hole must be oriented to ensure when a bolt is inserted, it will set against the bottom of the vertical slotted hole (**Fig.3A**).

10. Do the same to the other side of the hanger.

NOTE: Do not attempt to drill the pilot hole in the backside of the hanger by using the front hole as a guide. These holes must be perfectly aligned or the plates will not fit properly.

11. Repeat steps 2-9 for the remaining hangers, including the equalizer hangers.

12. Drill open all the $\frac{1}{4}$ " drilled holes to $\frac{9}{16}$ ". You may step directly up to a $\frac{9}{16}$ " drill — or if you find it easier — use a $\frac{3}{8}$ " bit prior to the $\frac{9}{16}$ " finished size.

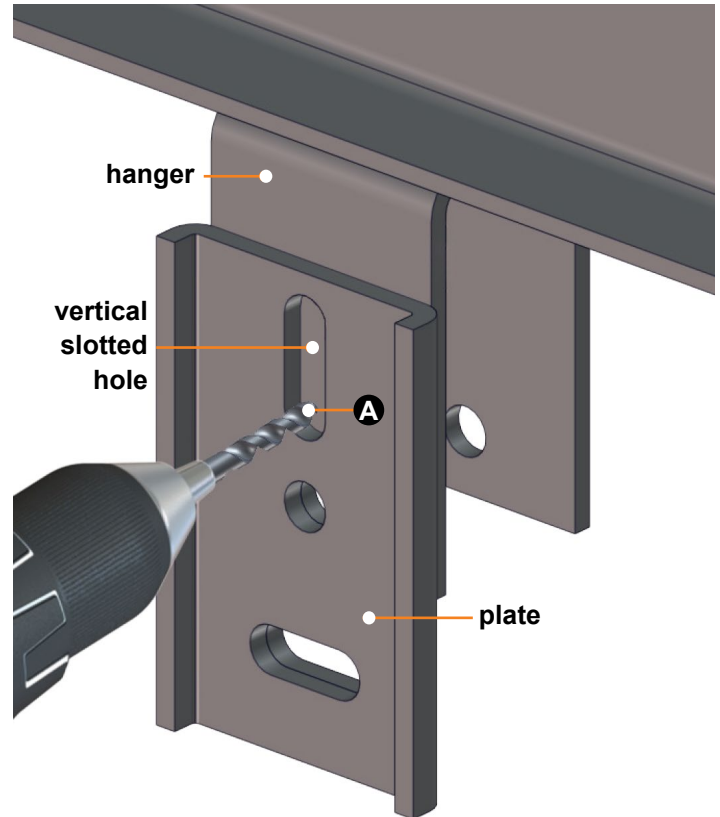

Fig.3



Installation

1. Place spring hanger plates on the outside of the spring hanger. Insert the 2" x 3" x 1 7/8" spacer in the center of the hanger. Align the center hole of the plate with the bottom hole of the hanger and insert a 9/16" x 2.82" bolt through the plate, spacer and hanger (**Fig.4**). Install a nut on the backside and snug it up so the assembly does not fall apart.

2. Use a 9/16" x 2.82" bolt and a washer to go through the upper slot, hanger spacer and drilled hanger holes. Install a nut and washer on the backside and snug up (**Fig.5 and Fig.6**).

3. Repeat steps 1 and 2 on the remaining hangers, both inside and outside the hangers.

4. Use jacks to raise the axle in order to bring the spring eye back into the hanger area.

5. Place an octagon cam on the plate on the hanger. The cam should hang down with the hole in the center from left to right. Place a second octagon cam on the plate on the other side of the hanger. Start the nut so the assembly doesn't fall apart. Make sure the cams are seated and locked between their side rails. This is done by slowly raising and/or lowering the axle and/or the trailer frame to move the cam into position (**Fig.7**).

6. Bolt the assembly together using a 9/16" x 3.32" bolt and a nut. Tighten the nut to a minimum of 30 ft-lbs of torque, up to a maximum of 50 ft-lbs of torque.

7. Repeat steps 5 and 6 on remaining spring hanger(s).

NOTE: Figure 8 shows the completed single axle Correct Track assembly.

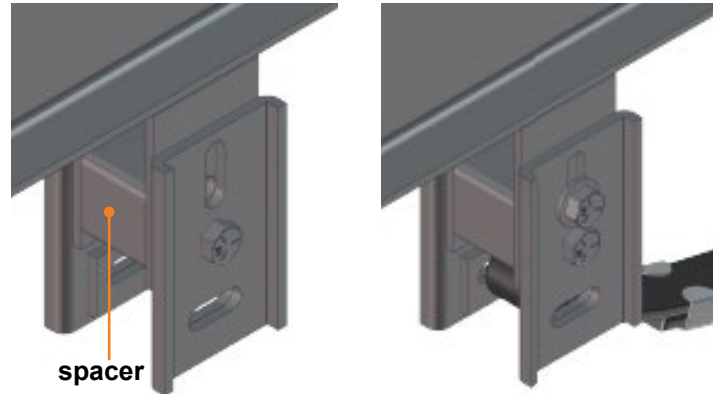

Fig.4

Fig.5

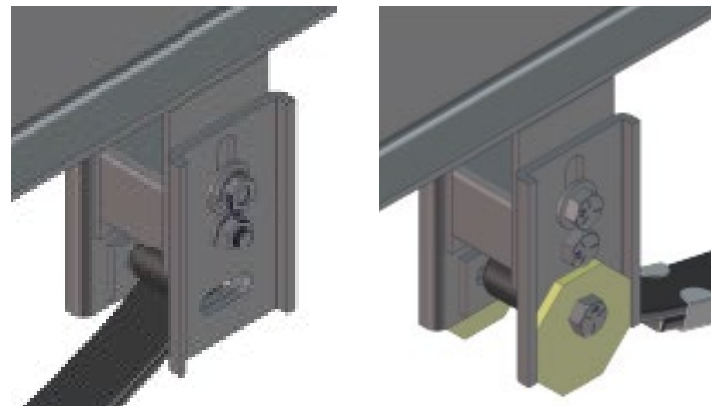

Fig.6

Fig.7

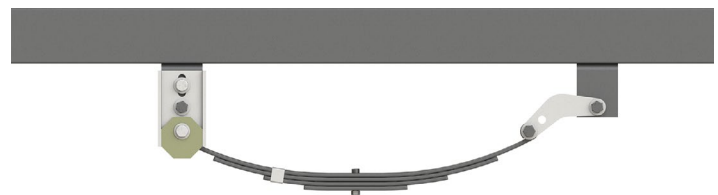

Fig.8



Correct Track™

Installation and Owner's Manual

(For Aftermarket Applications)

8. For tandem and triple axle installation, the process for installing the equalizer plates is the same as the outside four hangers with one exception: You must unbolt the equalizer and leaf springs before installing the Correct Track equalizer plates. The plates contain two circular holes and a vertical slot on the top. A horizontal hole is absent because there is no cam to install on the equalizer plates (**Fig.9, Fig.10 and Fig.11A**).

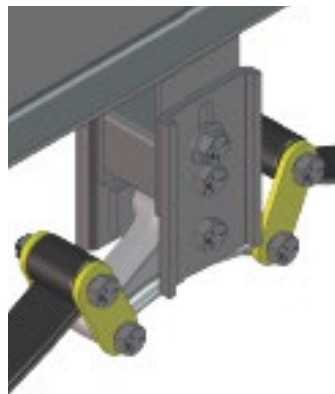

Fig.9

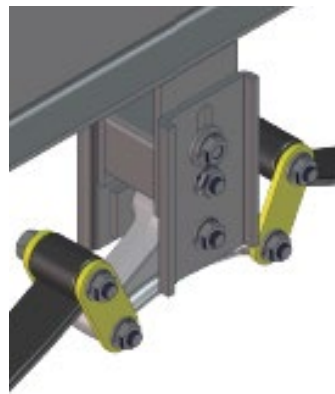

Fig.10

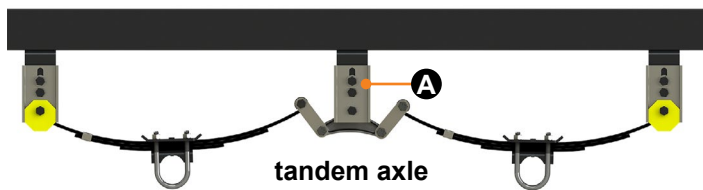

Fig.11

A. For the triple axle configuration the location will be the third hanger from the front (**Fig.12A**).

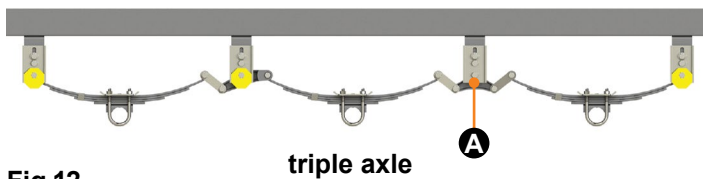

Fig.12

9. Tighten the nut to a minimum of 30 ft-lbs of torque, up to a maximum of 50 ft-lbs of torque.

10. Verify that all nuts and bolts are tightened properly.

11. Reinstall wheels.

12. Repeat instructions for the other side of the trailer

Manual Measurement

1. Park the trailer on level ground.

2. Use a plumb bob from the kingpin or coupler to mark a spot on the floor.

3. Measure with a tape measure from the front of the tire on either side to the mark on the floor. Record this measurement.

4. Take measurement from hub to hub. Measuring from the edge of one dust cap to the same edge of the other dust cap will result in the same center-to-center measurement (**Fig.13**).

A. For the triple axle measurement always measure from the front hub to the third hub.

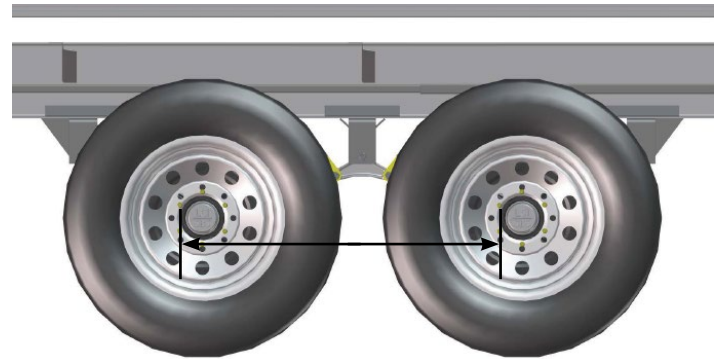

Fig.13

5. Do the same for the opposing side of the trailer.

6. Fill out the customer form with the measurements.

7. See Adjustment Procedures instructions.

NOTE: If a laser measurement is being used, see Laser Measurement Kit Assembly section.



LIPPERT
COMPONENTS®

Correct Track™ Installation and Owner's Manual (For Aftermarket Applications)

Laser Measurement Kit Assembly

Travel Trailer

NOTE: These procedures can only be performed by a certified dealer.

1. Install travel trailer main tube (17.5") on base (Fig.14).



Fig.14

2. Install alignment bracket and place the laser alignment tool on the alignment bracket (Fig.15).



Fig.15

3. Install stop bracket to allow extension up and down (Fig.16).

4. Install travel trailer upper tube (12") (Fig.17).

5. Install coupler adapter (Fits 2" - 2 5/16" Couplers) (Fig.18A).



Fig.16



Fig.17



Fig.18



5th Wheel

NOTE: These procedures can only be performed by a certified dealer.

1. Install 5th wheel tube on base (42") (Fig.19).
2. Install alignment bracket and place the laser alignment tool on the alignment bracket (Fig.20).
3. Install stop bracket to allow extension up and down (Fig.21).
4. Install 5th wheel upper tube (16") (Fig.22).
5. Install kingpin adapter. (Fig.23A).



Fig.19



Fig.20



Fig.21



Fig.22



Fig.23



Laser Measurement Procedure

1. Loosen bracket and raise tube up to meet the kingpin/ coupler (Fig.24).
2. Tap the base back and forth until the bubble is in the center (Fig.25).
3. Place the target in the center tread of the curb side front tire (Fig.26).
4. Repeat, placing the target on the street side front tire (Fig.27).

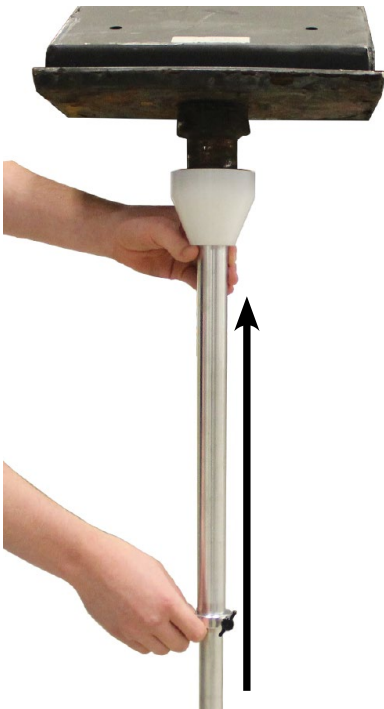

Fig.24



Fig.25



Fig.26



Fig.27



5. Align the laser with each target (**Fig.28**) and record the measurements on the customer form.
6. Measure the center-to-center distance between the hubs on both sides of the trailer. Measuring from the edge of one dust cap to the same edge of the other dust cap will result in the same center-to-center measurement (**Fig.29**).
 - A. For the triple axle measurement always measure from the front hub to the third hub.
7. Fill out the remainder of the customer form with the measurements.

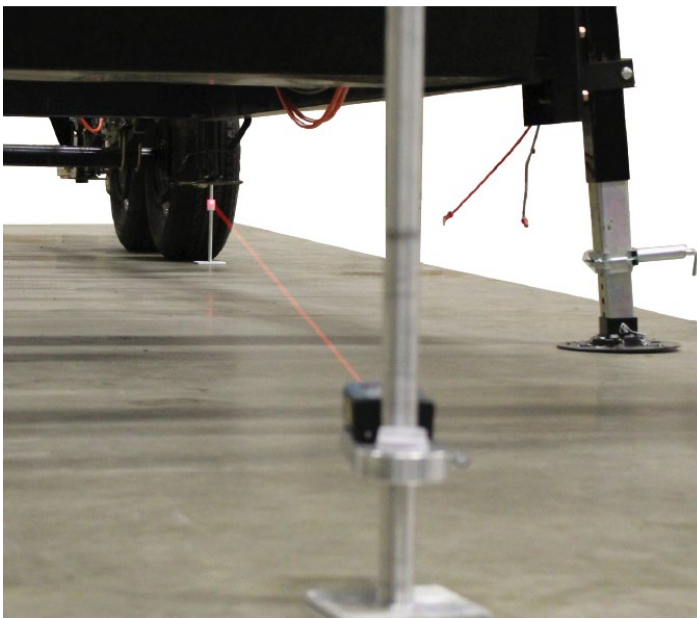

Fig.28

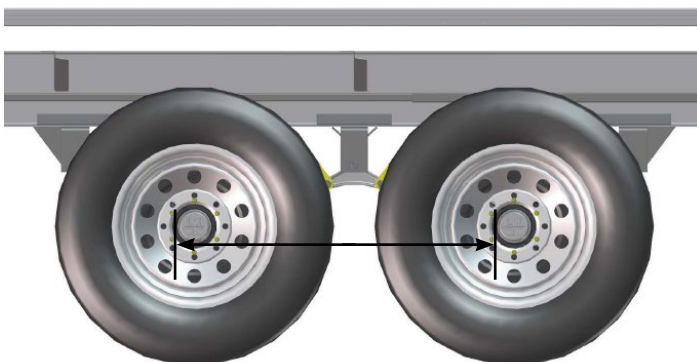

Fig.29

Adjustment Procedure

In order to determine how much to adjust the Correct Track system, you must consider the difference between the curbside measurements and the street-side measurements.

1. Release pressure on the cam bolt by jacking up the frame, making sure to stop just before the tire is lifted off the ground.

⚠ WARNING

LIFT TRAILER BY THE FRAME AND NEVER THE AXLE OR SUSPENSION. DO NOT GO UNDER TRAILER UNLESS IT IS PROPERLY SUPPORTED BY JACK STANDS. UNSUPPORTED TRAILERS CAN FALL, CAUSING DEATH OR SERIOUS INJURY.

2. Loosen nut from backside of cam bolt (**Fig.30**).
3. Tap end of bolt until the cam clears the locking tabs.
4. Rotate cam to get desired axle movement. When turned, each notch of the octagon equals $\frac{1}{4}$ " of adjustment. Rotate the cam to move the respective axle forward or rearward.

NOTE: Adjustments kingpin to curbside will affect the hub-to-hub measurements on each individual side and vice versa.

NOTE: Do not move the cam more than two notches either clockwise or counterclockwise.

NOTE: The jack may have to be adjusted up or down in order to get the cam aligned with the locking tabs on the hanger.

5. Take the trailer out for a short drive or move the trailer at least one tire revolution to stabilize the system.



Fig.30



LIPPERT
COMPONENTS®

Correct Track™
Installation and Owner's Manual
(For Aftermarket Applications)

Customer Form

Coupler/Kingpin to Curb Side Front Tire _____

Coupler/Kingpin to Street Side Front Tire _____

Difference _____

Curb Side Front Hub to 2nd Hub _____ Front to 3rd _____

Street Side Front Hub to 2nd Hub _____ Front to 3rd _____

Difference _____

Alignment Setting - Kingpin to 1st Tire

Curb: No. of Notches _____ Forward _____ Rearward _____

Street: No. of Notches _____ Forward _____ Rearward _____

Alignment Setting - Hub-to-hub

Curb: No. of Notches _____ Forward _____ Rearward _____

Street: No. of Notches _____ Forward _____ Rearward _____

Excessive Tire Wear, suspension damage

Any measurement over $\frac{3}{16}$ " out of alignment should be corrected.

A suspension of $\frac{1}{4}$ " out of alignment over the course of 5,000 miles is the equivalent of dragging the trailer 125 miles sideways!



Conducting Inspection & Written Report

Fill out form and get customer approval. Make sure ratings and GVWR are compatible.

Use your findings when presenting this report. Your alignment measurements will explain why the trailer's suspension is wearing tires and other components.

Safety Inspection Report

Customer Name _____

Work Order Number _____

Date _____ Technician _____

RV Type _____ Year _____ Model _____

Number of Axles _____ Axle Rating _____ GVWR _____

Customer Name _____ Customer Approval

Check, Correct, Note

Look for low pressure (rubber) stems on high pressure tires. Front tires should be same size, make, and tire pressure.

Note tire conditions and tread depth.

Tire Inspection

Valve Stem Type _____ Low Pressure _____ High Pressure _____

Curb Front PSI _____ Second Axle _____ Third Axle _____

Street Front PS _____ Second Axle _____ Third Axle _____

Curb Front Tread _____ Second Axle _____ Third Axle _____

Street Front Tread _____ Second Axle _____ Third Axle _____

Tire Wear Pattern Observed _____

Inspect Suspension Components

Inspect suspension components, look for holes becoming oblong in shackles and spring hangers.

Pull one bolt to check the condition of spring shackles and bushings.

Suspension Components Inspection

Curb Front Hanger _____ Second Hanger _____ Third Hanger _____

Street Front Hanger _____ Second Hanger _____ Third Hanger _____

Springs Curb Side _____

Springs Street Side _____

Shackles/Equalizers Curb Side _____

Shackles/Equalizers Street Side _____

